

AA1P presents a down-to-earth solution for a down-to-earth antenna. With a bit of effort you can improve your antenna, too.

How To Build An Effective All-Band Counterpoise

BY RICHARD BRUNNER*, AA1P

For several years I have been using a vertical antenna (Butternut HF9V-X) on all bands, 160 through 10 meters, using a simple all-band counterpoise with great satisfaction. A $1/4$ -wave or $3/4$ -wave vertical must have a counterpoise or ground grid to work properly and be effective, and here in New England, with thin rocky soil, a ground grid looks more like a 50 ohm dummy load (at least in my backyard)! Also, a counterpoise is much less trouble to install and gives performance comparable to a very extensive ground system.¹ This counterpoise will work very well with any antenna requiring a ground system, principally $1/4$ - or $3/4$ -wave verticals.

Everyone knows what a ground grid is—many (20 to 120) radials, $1/4$ wavelength long, laid on the ground or buried, and connected to the base of the vertical antenna. A counterpoise is a wire or system of a few wires suspended above ground. Both have their physical hazards. You haven't lived until you've tripped on your own ground grid. Always be wary and careful.

With a vertical antenna, the antenna currents return through the ground, causing series resistive losses. One way to minimize losses is to put many wires in or on the ground (ground grid), shorting-out the resistive path. The other way is to use a counterpoise, which keeps most of the electric field and return currents out of the ground, also minimizing losses. Counterpoises have been used with high-power VLF transmitters, and worked as well as or better than in-ground systems, depending on ground conductivity. They were eventually replaced with in-ground systems because of maintenance problems from ice storms and their occasionally starting field fires. The counterpoises were 10 feet off the ground.²

Purists will object that one radial (80

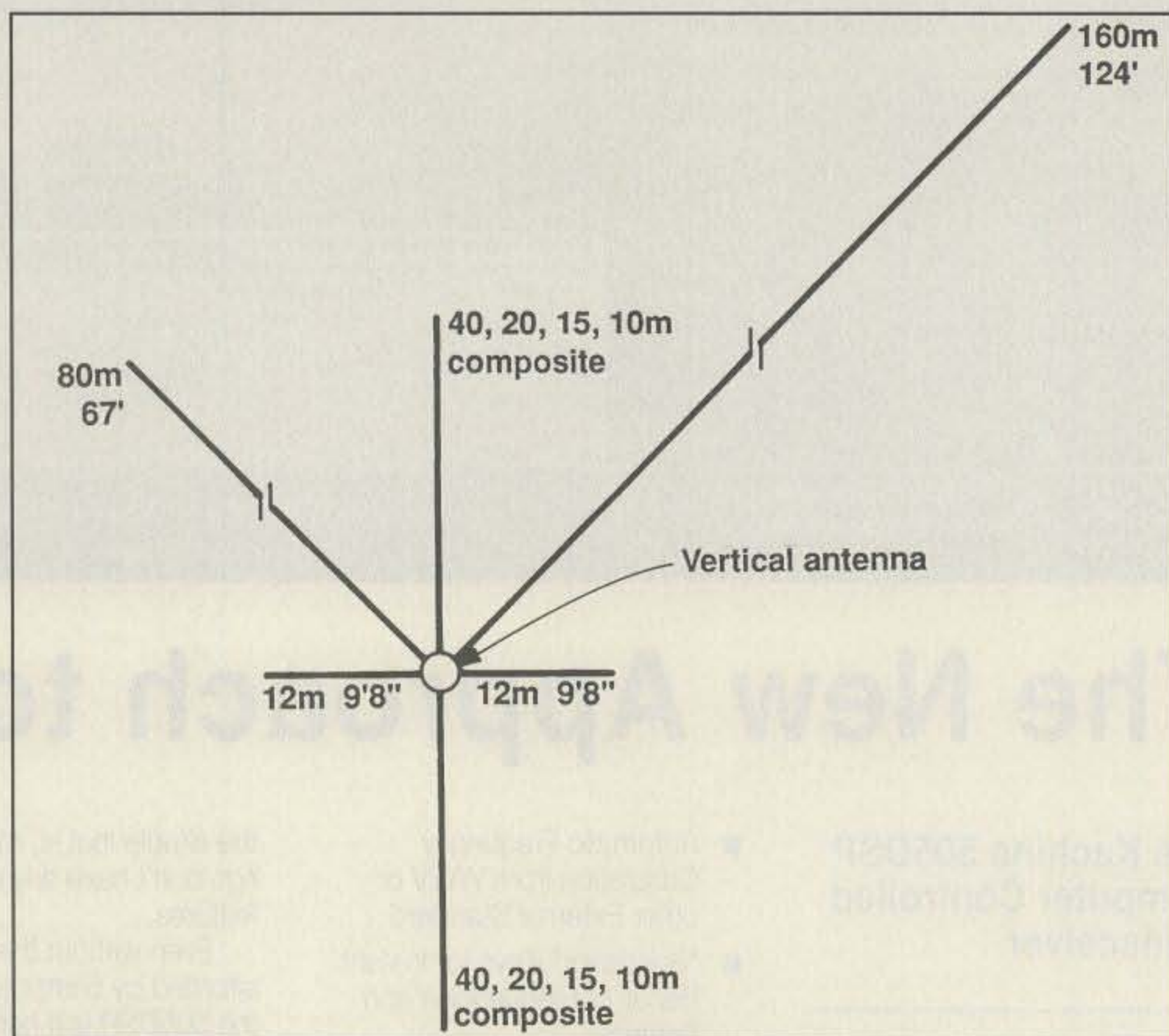

Fig. 1—The overall plan for the all-band counterpoise.

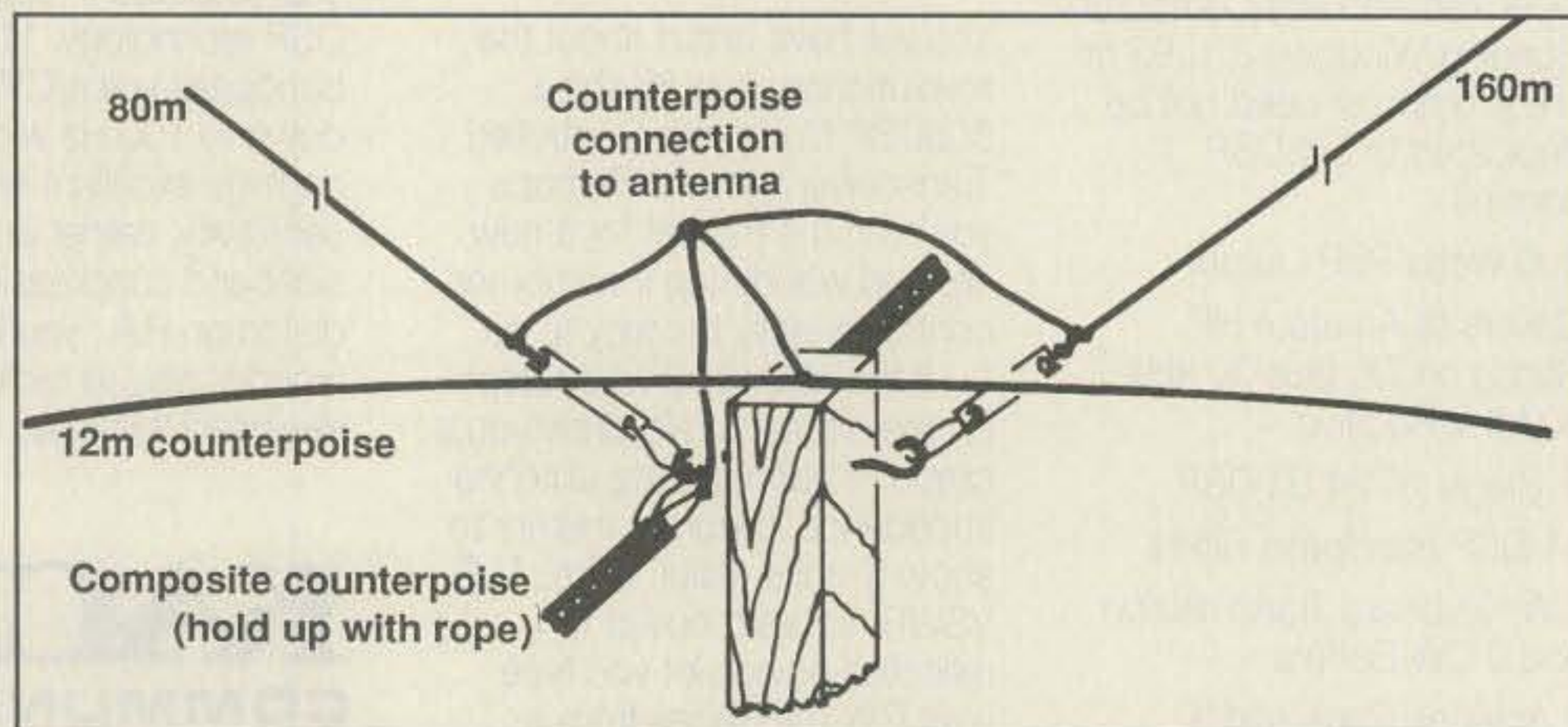

Fig. 2—How to connect the counterpoise to your vertical antenna.

*10 Brookside Drive, Foxboro, MA 02035
e-mail <richard.brunner@stoneweb.com>

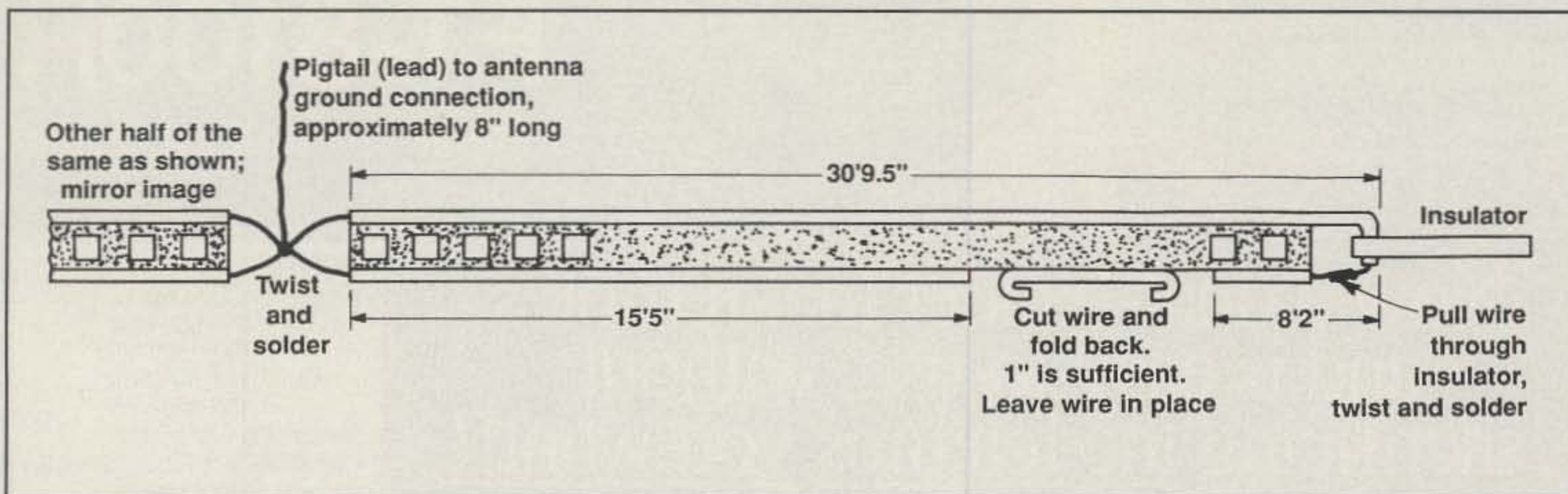

Fig. 3— The 40, 20, 15, and 10 meter ladderline counterpoise.

meters and 160 meters) is unbalanced and will permit horizontally polarized radiation from the counterpoise. That is true, as from a 10 foot high antenna, and we are in favor of radiation!

- For 160 and 80 meters I use *one* radial each. This is a variation on the old "1/4 wave up and 1/4 wave out," popular back in the 1920s. It worked well then and works well now. (See figs. 1 and 2.)

- For 40, 20, 15, and 10 meters I use a composite counterpoise made of 450 ohm

ladderline. One conductor is full length for 1/4-wave resonance on 40 meters and 3/4 wave on 15 meters, and one conductor is 1/4 wavelength for 20 meters. The long conductor is folded back to form a 10 meter stub, which isolates the first 3/4's to form 3/4 wavelength on 10. (See fig. 3.)

- No additional counterpoise is required for 30 and 17 meters, probably due to multiple wavelength resonance on the 80 and 160 meter counterpoises.

- 12 meters: Use two radials 9 ft. 8 in.

long. Actually, I used two radials from an old ground-plane, 9 ft. long with a 20 in. pigtail.

Place the counterpoise high enough off the ground so you cannot hang yourself on it. Mine is 10 ft. off the ground at the ends and something less in the middle of the spans. More height is acceptable. Another reason to keep it off the ground is because there is some coupling to the ground, and closer proximity will cause higher losses. I notice some detuning

This is no MIRAGE !



This Is Real !

TELETEC DXP Linear Amplifiers

Clearly the best all-mode amplifiers around.



DXR Model shown with meter option installed.

"Well constructed" "Designed to be installed and forgotten" QST October 1996

Model #	Freq.	Pwr Rating (In/Out) ★	Sugg. Retail	Model #	Freq.	Pwr Rating (In/Out) ★	Sugg. Retail
DXP-L180	6 meter	15W/180W	\$379.00	DXR-L180_	6 meter	15W/180W	\$639.00
DXP-V175	2 meter	50W/175W	\$329.00	DXR-V175_	2 meter	50W/175W	\$629.00
DXP-V220	220 MHz	20W/150W	\$369.00	DXR-V220_	220 MHz	20W/150W	\$659.00
DXP-U150	70 cm	30W/150W	\$429.00	DXR-U150_	70 cm	30W/150W	\$789.00

* Output Power level is determined by the input power level. Units will operate with input power level as low as 1 watt.

TELETEC's DXP Series Linear Amplifiers clearly outperform the competition. The die cast aluminum heat sink provides an attractive low profile, but powerful package. These amplifiers operate in all modes: FM, SSB, CW, and AM. Transmit/Receive Switching is automatic - RF sensed. Over/Reverse Voltage, Over-Temp, and VSWR protection are provided. Available Options include: ATV tuning, Repeater tuning, Preamp disable and keying wire kit. "N" connectors are also available (std on DXP-U150).

TELETEC's DXR Series Linear Amplifiers are 100% continuous duty packages available in Rack Mount or Desktop versions. Super quiet fans are used to keep the heatsink and internal components extremely cool. DXR series amplifiers provide the same operational features as the DXP series. "N" connectors standard on all DXR models.

"We meet or exceed all published specifications, - We GUARANTEE IT"

Contact your dealer for your best pricing !

12 Month Warranty -- VISA/MASTERCARD Accepted

Prices and specifications subject to change without notice.

For more information, call or write: 10101 Capital Blvd., Wake Forest, NC 27587 - USA
 Order Line: Toll Free (888) 323-6888 Technical: (919) 556-7800 Fax: (919) 556-6180
 E-mail Address: teletec@sprintmail.com Website Address: www.teletec-usa.com



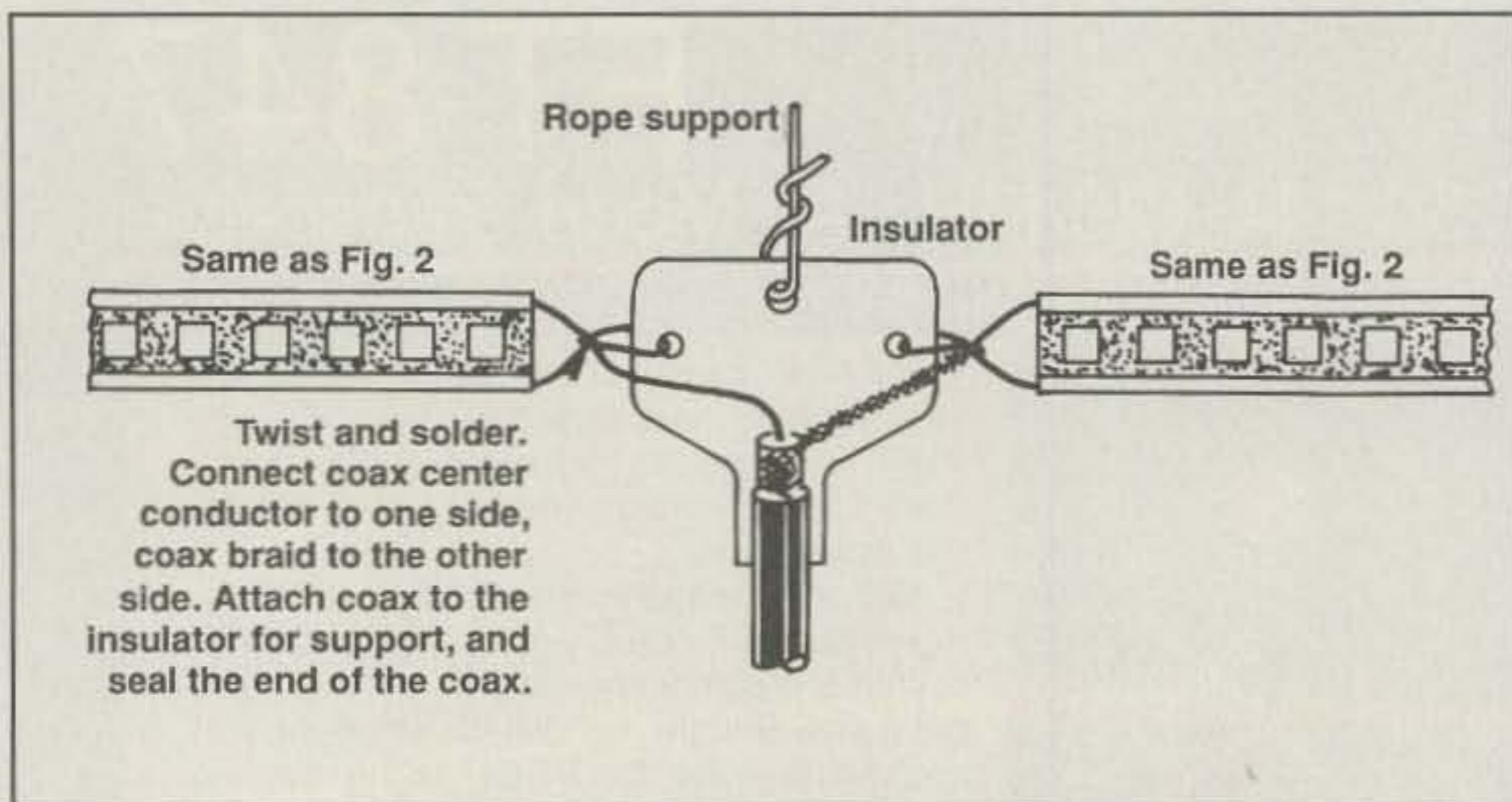

Fig. 4— The "ladderline" 4-band dipole for 40, 20, 15, and 10 meters.

(lower resonant frequency) when the ground is wet, but it is not a problem.

In constructing the counterpoise, the ends must be insulated the same as for any wire antenna. Strictly speaking, the ends of the counterpoise wires at the antenna are at ground potential and need not

be insulated, but I insulate them anyway where possible to assure control of where the RF currents are going, and to prevent conductors rubbing together causing strange noises in the receiver. Also, cover your soldered joints with Vaseline® or grease or something, or in a few years the

solder will deteriorate and you will have non-performing joints. The leads shown as "Pigtails" in the figures are merely short lengths of wire connecting the counterpoise elements to the antenna, in my case to the coaxial cable braid.

When installing the counterpoise elements, space them as far apart as practicable (see fig. 1). If they are too close together they will couple with unpredictable results. I originally suspended the 12 meter wires beneath the ladderline elements, and could not achieve 15 meter resonance on the antenna! Rotating the 12 meter elements 90 degrees solved the problem.

Note that the composite counterpoise will also make a good four-band dipole if fed in the center with coaxial cable (but not at the same time). With the dimensions given, resonance was measured at 7.1, 14.12, 21.23, and 28.47 MHz (see fig. 3). Seal the end of the coaxial cable, because you will have very bad results if water gets into your cable. Coax is heavy, so this antenna should be supported at the center.

For composite design of the ladderline counterpoise/antenna, other frequencies may be easily calculated:

- 1/4 wavelength resonance: $L \text{ (ft.)} = (246/f(\text{MHz}) \times \text{VF} \times \text{end effect})$
- 3/4 wavelength resonance: $L \text{ (ft.)} = 2(246/f(\text{MHz}) \times \text{VF}) + (246/f \text{ MHz} \times \text{VF} \times \text{end effect})$
- 3/4 wavelength resonance with isolation stub: $3(246/f(\text{MHz}) \times \text{VF}) + \text{stub} = \text{approx. } 4(246/f(\text{MHz}) \times \text{VF})$

VF = Velocity Factor, 0.92 for 450 ohm ladder line (measured)

End effect = 0.97 (3%)

One could also use 300 ohm ribbon using a VF of 0.75, but it is not recommended. The conductors are easily broken, and then it stretches like taffy!

By now you are wondering if the counterpoise really works. The answer is yes! My first contact on 80 meters was a G3 (England), and on the higher bands it works as well as any antenna I've ever had. On 30 meters I easily worked Australia and Japan, and on 20 meters I worked the South Pole through a pileup with 100 watts! On 160 meters a short vertical antenna is inferior to a horizontal "Cloud Warmer" for nearby contacts, and usable bandwidth is narrow (12 kHz), but I have had many good contacts, and DX is always a possibility.

References

1. *Build Efficient, Short Vertical Antennas*, Thomas Kuehl, AC7A, QST, March 1998, pp. 39-44.
2. *Antenna Engineering Handbook*, Henry Jasik, McGraw-Hill Book Co., 1961, Section 19.4, Low-Frequency Ground Systems.

BUTTERNUT

HF5B BUTTERFLY BEAM ANTENNA

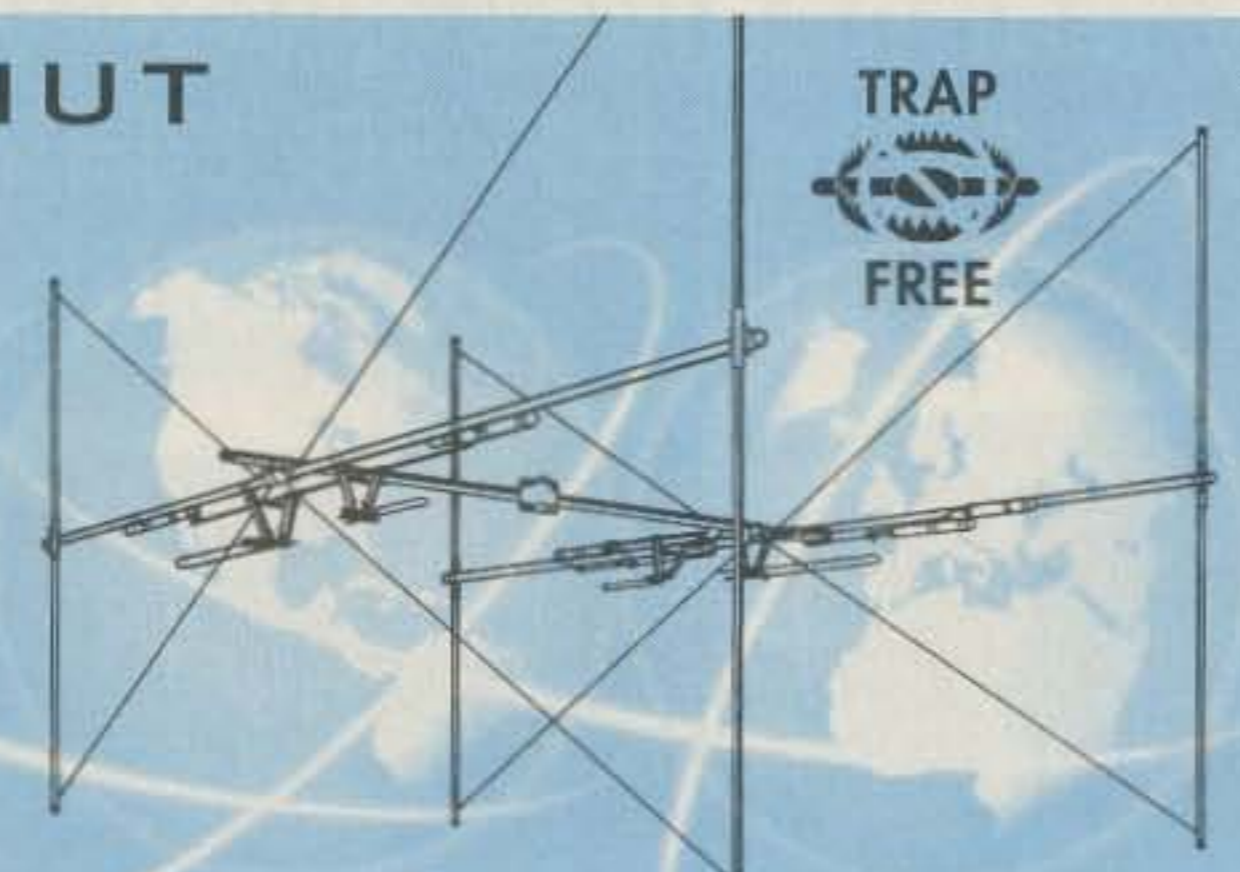

If you hunger for a directional antenna, but can't put up a full-size Yagi...

WE'VE GOT THE ANSWER!

Designed for the amateur with limited space, it offers significant improvement over omnidirectional antennas. Light enough to turn easily with a standard TV antenna rotator, it mounts easily on a mast or roof tripod.

Call or write for Free New Color Brochure!
(Ask for the designers Dirty Little Secrets!)

630-238-1183

831 N. Central Avenue, Wood Dale, IL 60191
Fax: 630-238-1186
<http://www.bencher.com> email: bencher@bencher.com

TRAP FREE

Wingspan: 12 ft. 6 in. (3.8m)
Boom Length: 6 ft. (1.8m)
Turning Radius: 6 ft. 11 in. (2.1m)
Vert. Spreaders: 6 ft. (1.8m)
VSWR @ Resonance: 1.5:1 or less all bands
Frequency: 10, 12, 15, 17, 20M
Minimum Height: 30 ft. (9.1m)



butternut
ANTENNAS

CIRCLE 41 ON READER SERVICE CARD